

THIS DRAWING IS UNPUBLISHED. RELEASED FOR PUBLICATION
 © COPYRIGHT 19 BY TYCO ELECTRONICS CORPORATION. ALL RIGHTS RESERVED.

LOC		DIST		REVISIONS			
P	LTR	DESCRIPTION	DATE	DWN	APVD		
	A	RELEASE TO ACTIVE	07JUN2006	BB	SB		

1 MATERIAL:
 HOUSING: DIECAST ZINC, NICKEL PLATED
 ALIGNMENT SLEEVE: SEE DASH NO'S
 PROTECTIVE COVER: TPE, COLOR: BLACK.*
 RETENTION CLIP: STAINLESS STEEL
 PROTECTIVE COVER: VINYL
 RETAINER: PEI-GF30, COLOR: BLACK.*
 *UL94 V-0 RATED AT QUALIFYING THICKNESS.

2 BULK PACKAGE.

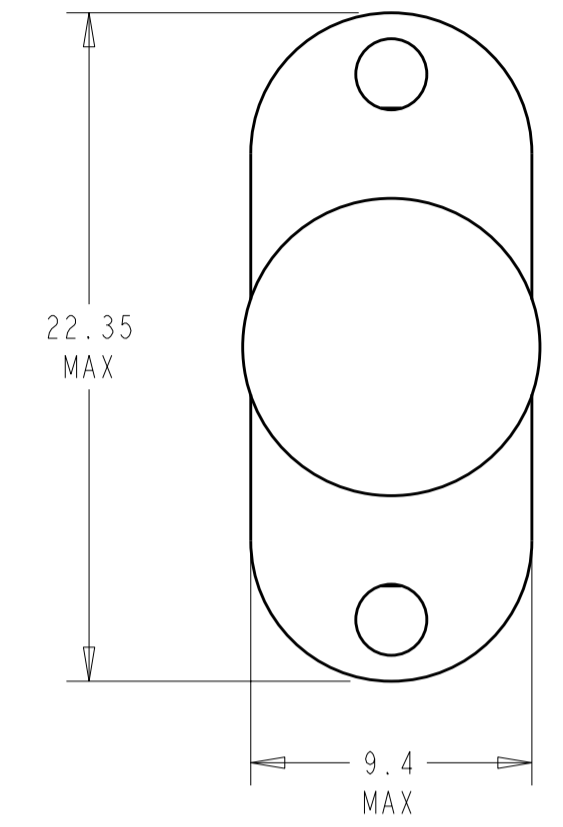
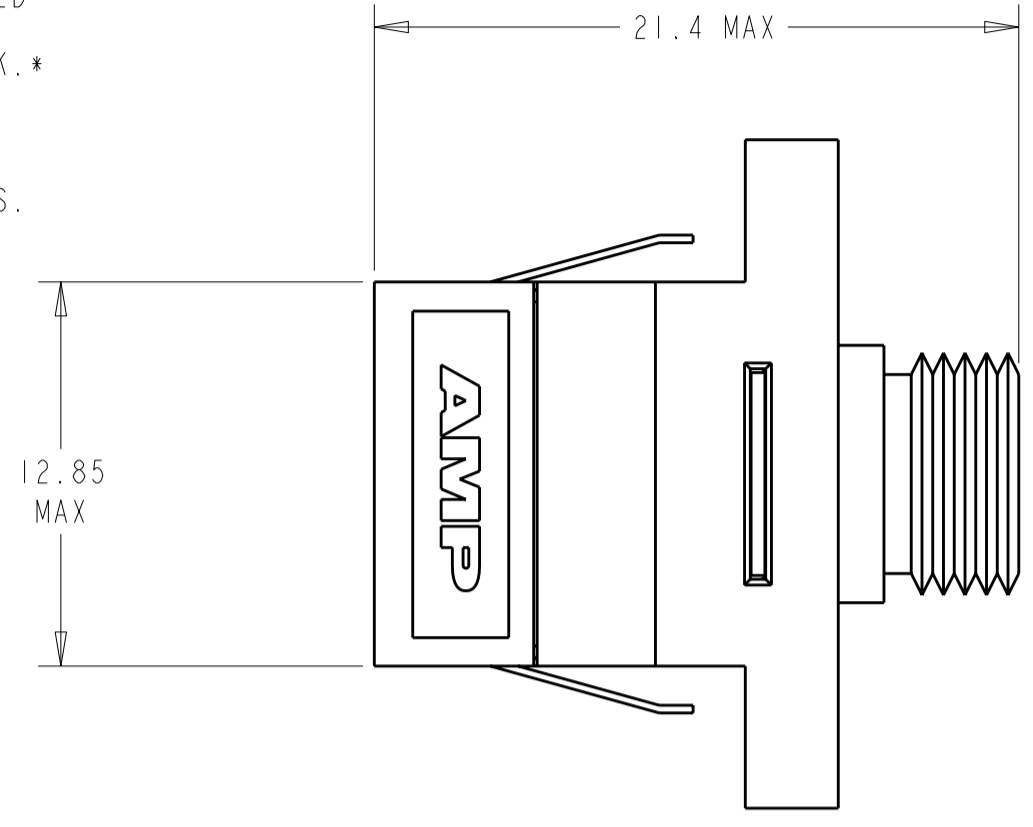

2-56UNC-2B, OR M2 X 0.4 -6H
 2x, WHEN REQUIRED

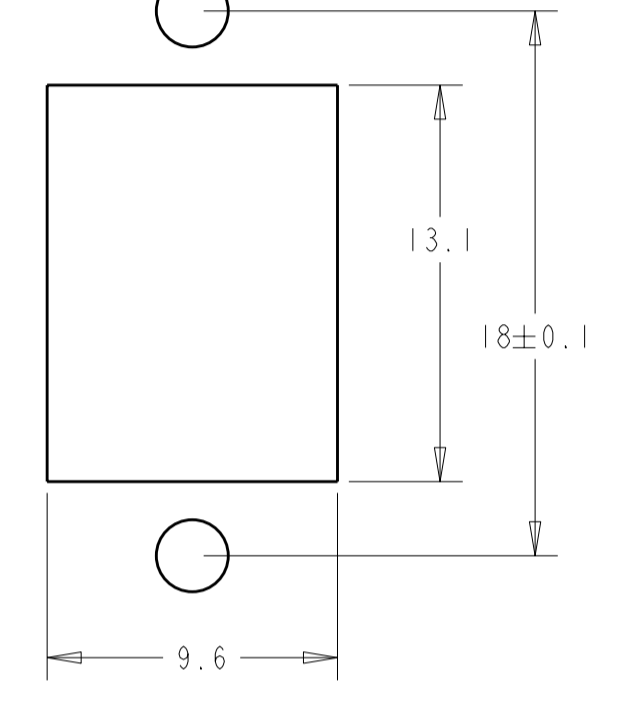

SUGGESTED PANEL CUTOUT
 MAX PANEL THICKNESS 1.7

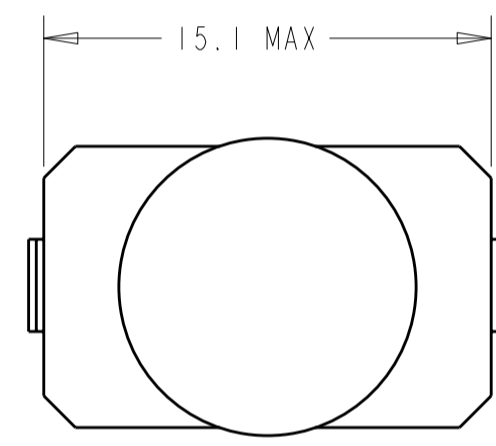

FLANGELESS STYLE

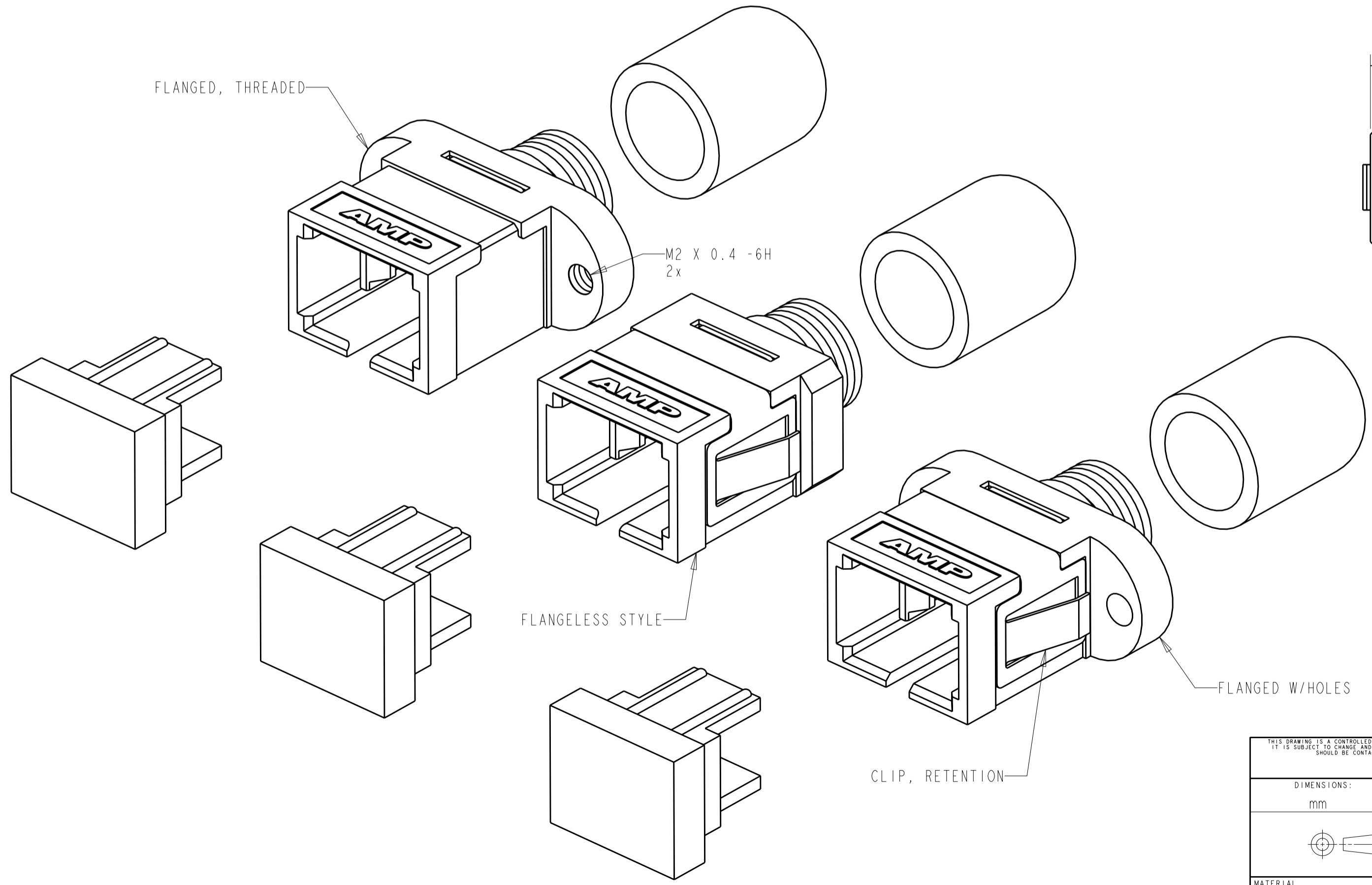

ALIGNMENT SLEEVE	DESCRIPTION	PART NO	
2	CERAMIC	THREADED FLANGE, NO CLIP	1-6278349-2
2	CERAMIC	FLANGED W/HOLES, NO CLIP	1-6278349-1
2	CERAMIC	FLANGELESS, NO CLIP	1-6278349-0
2	METAL	FLANGED W/HOLES, NO CLIP	6278349-9
2	CERAMIC	FLANGELESS	6278349-8
2	CERAMIC	FLANGELESS	6278349-7
2	METAL	FLANGELESS	6278349-6
2	METAL	FLANGELESS	6278349-5
2	CERAMIC	FLANGED W/HOLES	6278349-4
2	CERAMIC	FLANGED W/HOLES	6278349-3
2	METAL	FLANGED W/HOLES	6278349-2
2	METAL	FLANGED W/HOLES	6278349-1

THIS DRAWING IS A CONTROLLED DOCUMENT FOR TYCO ELECTRONICS CORPORATION
 IT IS SUBJECT TO CHANGE AND THE CONTROLLING ENGINEERING ORGANIZATION
 SHOULD BE CONTACTED FOR THE LATEST REVISION.

DWN B. BRIGGS 17MAY2005
 CHK S. MILLER 17MAY2005
 APVD S. BUCHTER 17MAY2005

AMP Incorporated
 Harrisburg, PA 17105-3608

NAME ASSEMBLY, RECEPTACLE, SC/FC
 SIMPLEX, DIECAST HOUSING

SIZE A2 CAGE CODE 00779 DRAWING NO. 6278349 RESTRICTED TO -
 WEIGHT - SCALE 4:1 SHEET 1 OF 1 REV A

CUSTOMER DRAWING